

## GENERAL DESCRIPTION

EK-WL8-OH is a wireless multi sensor that incorporates a smoke and heat sensor (A1R).

The device analyzes physical factors associated with fire and the way these factors change through time. An alarm signal is generated when the smoke level inside the optical chamber exceeds a certain threshold or the air temperature exceeds a threshold value.

The advanced design of the optical chamber guarantees a very high level of dust protection, effectively increasing the time between maintenance procedures.

The thermal sensor is A1R type.

The device is supplied with a mounting kit.

The product complies with the requirements of the AS ISO 7240.7, AS ISO 7240.5, AS ISO 7240.15:2004 and AS ISO 7240.25 standards.



## FEATURES

- Bi-directional wireless communication
- Intelligent algorithms
- Tamper switch
- 10-year battery life
- Self-optimizing wireless frequency and amplitude algorithms
- Patented smoke chamber design

## GENERAL OVERVIEW

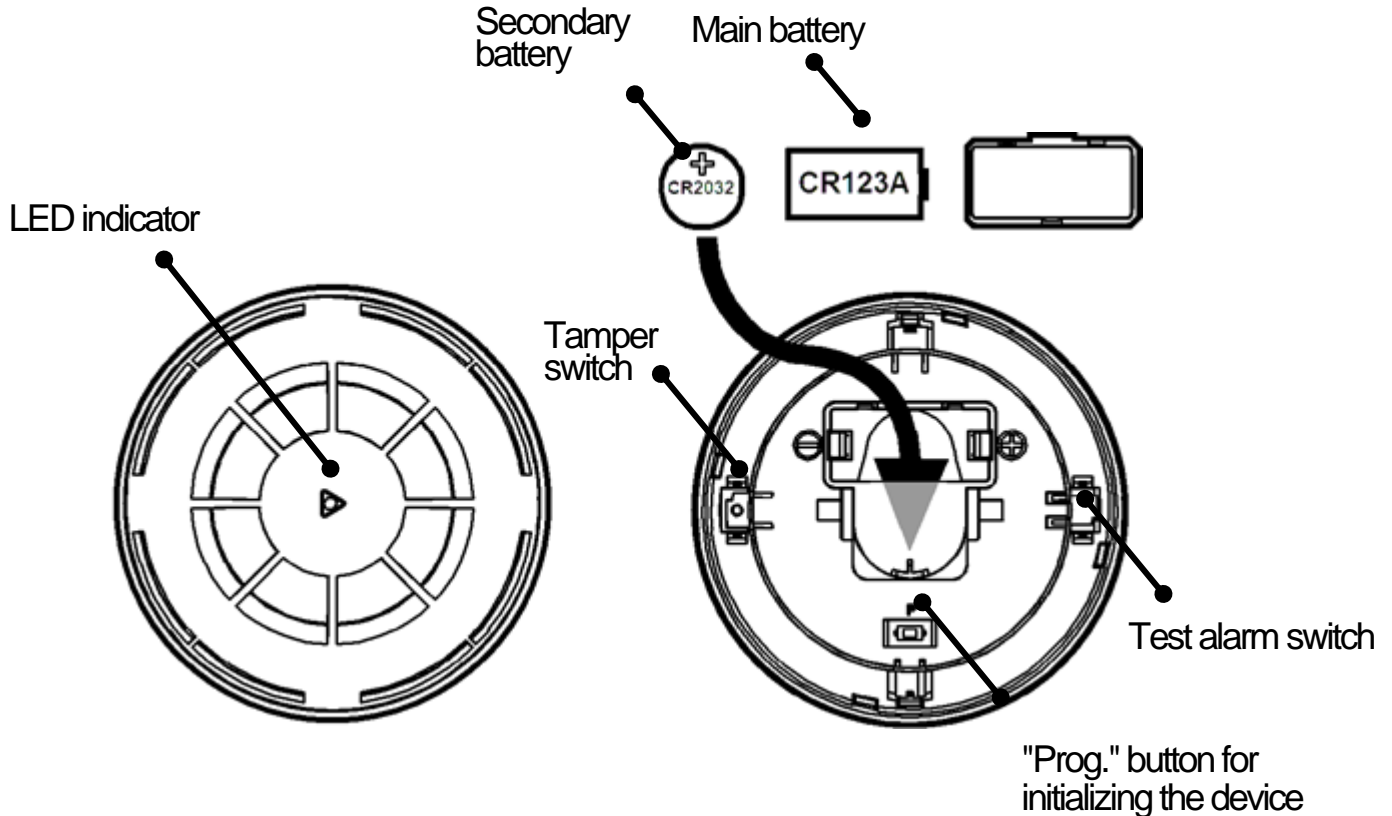

## TECHNICAL SPECIFICATIONS

Communication range with a translator or expander	1200 m
Radio frequency	918-926 MHz
Modulation type	GFSK
Operating frequency channels	6
Radiated power	Not more than 25 mW
Receiver category (EN300-220-1)	1.5
Battery life:	
Primary battery (type CR123A)	8-10 years
Secondary battery (type CR2032)	Not less than 3 months (after primary battery low fault)
Dimensions (with the base)	111 mm x 65 mm
Weight	160 g
Max tolerated humidity	95% RH
Operating temperature range	From -10 °C to +55 °C

**NOTE** Check the latest version of the product specification document STFV.425238.032-E-PS for further data, obtainable from the manufacturer

## PROGRAMMING

The “Prog.” button on the device is used for initializing the device on to the system. Please refer to the translator manual for full instructions on how to add a device to the system. The device can also be initialized using the “Ekho Configuration” software.

## INSTALLATION

In order to install the device, the mounting base should be fixed to the ceiling, the sensor can then be inserted into the base by rotating the sensor until it clips into the base

Preferably, the device should be installed away from metallic objects, doors, and power lines, as they can cause the communication distance to drop. It is also important to avoid installing the device near electronics and computer equipment in order to protect them from potential electromagnetic interference.

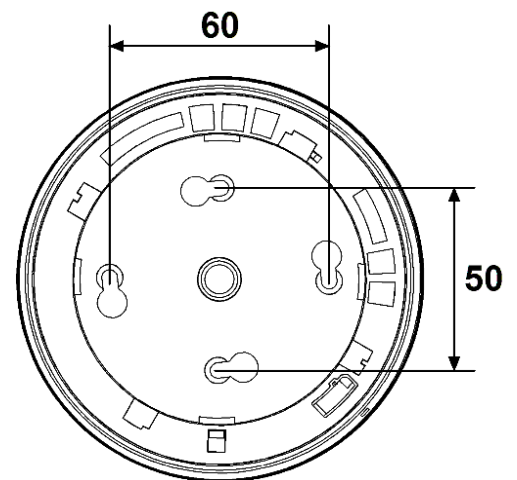

## INDICATION

The device has a LED which indicates its state according to the following:

LED indication	Device's state
No indication or green flashes	Standby mode
Yellow flashes every 4 seconds	Fault state – low battery or malfunctioning smoke or thermal sensor
Red flashes every 2 seconds	Fire alarm

When the device is powered up, an automatic calibration process will begin, this lasts around one minute and is indicated with a red flashing LED.

## SMOKE SENSITIVITY

Smoke sensitivity level can be changed in translator menu.

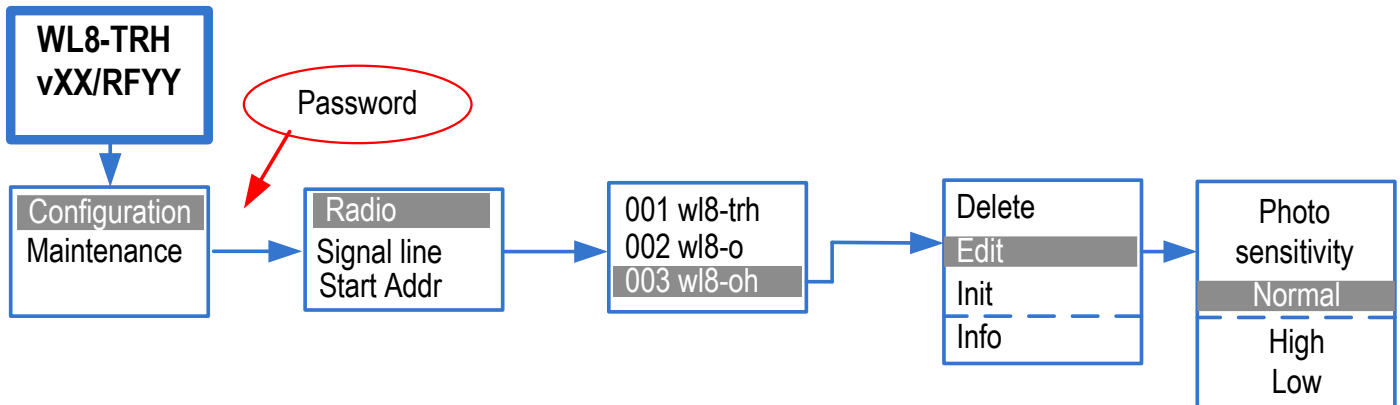

3 sensitivity options are available, these can be selected only by using the translator menu or the Ekho configurator software (setting via the control panel will have no affect and sensor will remain in the selected mode).

## TESTING

An alarm test can be performed with a magnet by placing it onto the outside of the sensor (opposite side to the base alignment marks) the sensor should take around 1 second to activate.

A suitable smoke or heat test tool can also be used, please follow the instructions to apply smoke/heat to the sensor in the correct way.

## ANALOG DATA

The device provides the translator module with analog data about the current smoke level, air temperature, dust in the chamber and voltage levels of its batteries. This information can be viewed in the “Ekho Configuration” software.

Sensor	Partition	Primary supply	Standby supply	Temperature	Analog. type 1	An. value 1
3 WL8-OH	003: Partition	3.1 V	3.3 V	25 °C	Smoke	31

By analyzing the voltage or dust levels you can manage maintenance procedures and predict when you will have to replace the batteries or clean the smoke sensor. Please refer to the software manual for full instructions on how to use the Ekho Configurator for system maintenance.



## WARNINGS & LIMITATIONS

Devices use high quality electronic components and plastic materials that are highly resistant to environmental deterioration. However, after 10 years continuous operation it is advisable to replace them to reduce the risk of reduced performance caused by external factors. Ensure the devices are only used with compatible control panels. Detection systems must be checked, serviced, and maintained on a regular basis to confirm correct operation.

Refer to and follow National Codes of Practice and other internationally recognized fire engineering standards. Appropriate Risk Assessment should be carried out initially to determine correct design criteria and updated periodically.

## WARRANTY

All devices are covered by a 3-year limited warranty (does not apply to batteries). The warranty is voided by mechanical or electrical damage caused by incorrect handling or usage. Product must be returned via an authorized supplier for repair or replacement along with full information on the identified problem.

## BATTERY REPLACEMENT

**When a battery requires replacement, both batteries must be changed together.**

- a. Remove the sensor from the base.
- b. Clip off the battery cover and remove the batteries.
- c. Insert the new batteries as detailed in the installation manual above – take care to observe + / - polarity.
- d. Re-fit the battery cover and re-insert the sensor into the base.
- e. Test the sensor in accordance with the manufacturer's instructions.

It is recommended to change both batteries after 10 years of operation regardless of their indicated discharge level.

To replace the batteries, use Panasonic CR123A (primary battery) and Varta CR2032 (secondary battery) or other with similar characteristics. The batteries must meet the following standards: UL 1642 lithium batteries, UL certified at [www.ul.com](http://www.ul.com) or IEC 60086-4 Primary batteries, Part 4: Safety of lithium batteries.

The remaining shelf time of the new batteries must be not less than 8 years.

	<b>EK-WL8-OH/AU WIRELESS MULTI-SENSOR SENSOR</b>	
<b>STFV.425238.032-AU-UM rev. 16</b>	<b>10.08.2020</b>	<b>Page 6 from 7</b>

Failure to observe these instructions will void the device warranty and any liabilities.

### **CAUTION**

- Replacement of a batteries must be of the same type.
- Do not expose used batteries to fire, hot ovens, or mechanical crushing/ cutting as this can result in an explosion.
- Exposing batteries to extremely high environmental temperatures can result in explosion or the leakage of flammable liquid or gas.
- A battery subjected to extremely low air pressure may result in an explosion or the leakage of flammable liquid or gas.

### **DISPOSAL**

- Follow local regulations regarding disposal of the batterie



**EK-WL8-OH/AU  
WIRELESS MULTI-SENSOR SENSOR**

**STFV.425238.032-AU-UM rev. 16**

**10.08.2020**

**Page 7 from 7**



**Australian  
Standard**

SAI Global

Lic SMK 41078



ABN No

67 153 750 648

**Hochiki Australia Pty Ltd**

Block Y, Unit 1 Regents Park Estate  
391 Park Rd, Regents Park  
NSW 2143, Australia

Telephone: +61 2 9738 5566

Web: [www.hochikiaustralia.com](http://www.hochikiaustralia.com)

Email: [sales@hochikiaustralia.com](mailto:sales@hochikiaustralia.com)